

Bimetal thermometer Model 52, industrial series

WIKA data sheet TM 52.01



for further approvals
see page 5

Applications

- A wide range of applications in machine building, vessel, piping and apparatus construction
- Domestic and industrial heating

Special features

- Scale ranges from -30 ... +500 °C
- Large selection of nominal sizes from 25 ... 160 mm
- Case and stem from stainless steel
- 5 different connection designs



Bimetal thermometer, model A52.100

Description

Thermometers of this series are designed for fitting into vessels and pipelines.

Designs with and without thermowells offer many application possibilities for temperature measurement in liquid and gaseous media.

Operation in hazardous areas is possible without Ex-specific marking in zone 1 and 2 (gases, ignition groups IIA, IIB, IIC).

Standard version

Measuring element

Bimetal coil

Nominal size in mm

25, 33, 40, 50, 63, 80, 100, 160

Connection design

S Standard (male thread connection)

1 Plain stem (without thread)

2 Male nut ¹⁾

3 Union nut ¹⁾

4 Compression fitting (sliding on stem) ¹⁾

¹⁾ Not for NS 25, 33, 40, 50

Models

Model	NS	Design
A52.025	25	Back mount (axial)
A52.033	33	
A52.040	40	
A52.050	50	
A52.063	63	
A52.080	80	
A52.100	100	
A52.160	160	
R52.063	63	Lower mount (radial)
R52.080	80	
R52.100	100	
R52.160	160	

Accuracy class

NS 25, 33: ±5 % of scale range

NS 40, 50: 2 per EN 13190

NS 63, 80, 100, 160: 1 per EN 13190

Working range

Continuous loading: Measuring range per EN 13190

Short time (24 h max.): Scale range per EN 13190

Scale range, measuring range ²⁾, error limit (EN 13190)

Scale graduation per WIKA standard

Scale range in °C	Measuring range in °C	Scale spacing in °C		Error limit ±°C	
		up to NS 63	from NS 80	up to NS 50	from NS 63
-30 ... +50	-20 ... +40	1	1	2	1
-20 ... +60	-10 ... +50	1	1	2	1
0 ... 60	10 ... 50	1	1	2	1
0 ... 80	10 ... 70	1	1	2	1
0 ... 100	10 ... 90	2	1	2	1
0 ... 120	10 ... 110	2	1	4	2
0 ... 160	20 ... 140	2	2	4	2
0 ... 200 ³⁾	20 ... 180	5	2	4	2
0 ... 250 ³⁾	30 ... 220	5	2	5	2.5
0 ... 300 ⁴⁾	30 ... 270	5	2	-	5
0 ... 400 ⁴⁾	50 ... 350	5	5	-	5
0 ... 500 ⁴⁾	50 ... 450	5	5	-	5

²⁾ The limits of the measuring range are indicated on the dial by two triangular marks.
Only within this range is the stated error limit valid per EN 13190.

³⁾ Not for NS 33

⁴⁾ Not for NS 25 to NS 50

Case, bezel ring, stem, process connection and spacer

Stainless steel

Elbow behind the case

Aluminium, only with lower mount version

Dial

Aluminium, matt, black lettering

Window

Instrument glass

NS 33: polycarbonate

Pointer

NS 25, 33, 40: Aluminium, black

NS 50, 63, 80, 100, 160: Aluminium, black, adjustable pointer

Permissible pressure rating at the stem

NS 25, 33, 40, 50: max. 6 bar, static

NS 63, 80, 100, 160: max. 25 bar, static

Ingress protection

NS 25, 33, 40: IP 54 per EN 60529 / IEC 529

NS 50, 63, 80, 100, 160: IP 43 per EN 60529 / IEC 529

Options

■ Scale range °F, °C/°F (dual scale)

■ Other scale ranges

■ Other connection types

Connection design

Design standard (male thread connection)

Standard insertion length $l_1 = 63, 100, 160, 200, 250$ mm

Nominal size NS	Process connection		Dimensions in mm		
	G	i	SW	d_4	$\varnothing d$
25, 33	M8 x 1.25	8	12	-	4
	G 1/8 B	8	12	-	4
	G 1/4 B	8	17	-	4
40, 50	M8 x 1.25	8	12	-	4
	G 1/8 B	8	17	-	4
	G 1/4 B	8	17	-	4
	G 1/2 B	12	22	-	4
63, 80, 100, 160	G 1/4 B	12	19	18	6, 8
	G 1/2 B	14	27	26	6, 8
	M18 x 1.5	12	24	23	6, 8
	1/2 NPT	19	22	-	6, 8

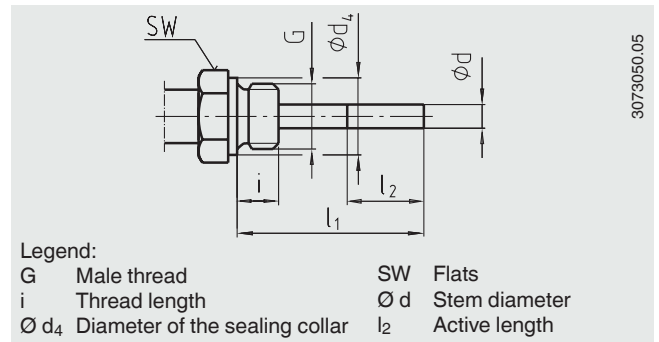

Design 1, plain stem (without thread)

Standard insertion length $l_1 = 45, 63, 100, 140, 160, 200, 240, 290$ mm

Nominal size NS	Dimensions in mm	
	d_1	$\varnothing d$
25, 33	8	4
40, 50	12	4
63, 80, 100, 160	18	6, 8

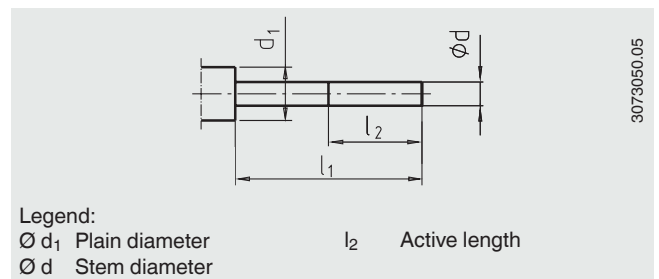

Design 2, male nut

Standard insertion length $l_1 = 80, 140, 180, 230$ mm

Nominal size NS	Process connection		Dimensions in mm	
	G	i	SW	$\varnothing d$
63, 80, 100, 160	G 1/2 B	20	27	6, 8
	M18 x 1.5	17	22	6, 8

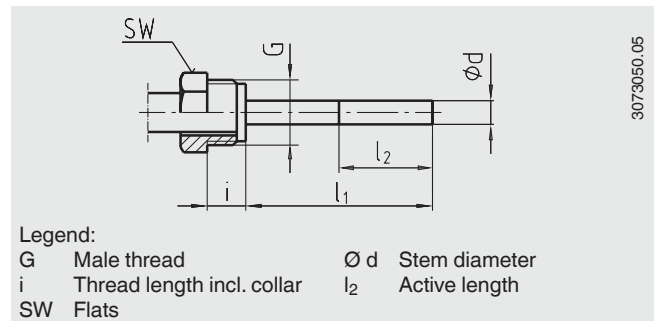

Design 3, union nut

Standard insertion length $l_1 = 89, 126, 186, 226, 276$ mm

Nominal size NS	Process connection		Dimensions in mm	
	G_1	i	SW	$\varnothing d$
63, 80, 100, 160	G 1/2	8.5	27	6, 8
	G 3/4	9.5	32	6, 8

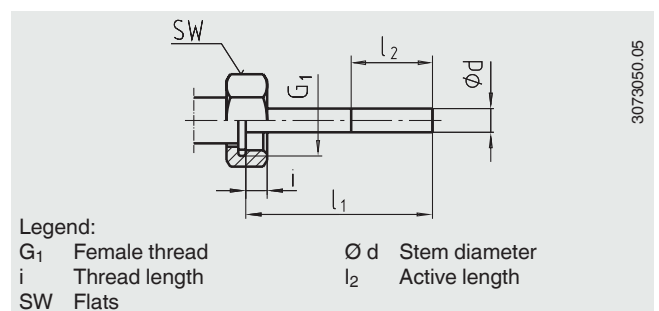

Design 4, compression fitting (sliding on stem)

Insertion length l_1 = variable

Length $L = l_1 + 40$ mm

Nominal size NS	Process connection		Dimensions in mm		
	G	i	SW	d_4	$\varnothing d$
63, 80, 100, 160	G ¼ B	8	22	18	6, 8
	G ½ B	14	27	26	6, 8
	M18 x 1.5	12	24	23	6, 8
	½ NPT	19	22	-	6, 8
	G ¾ B	16	32	32	6, 8
	¾ NPT	20	30	-	6, 8

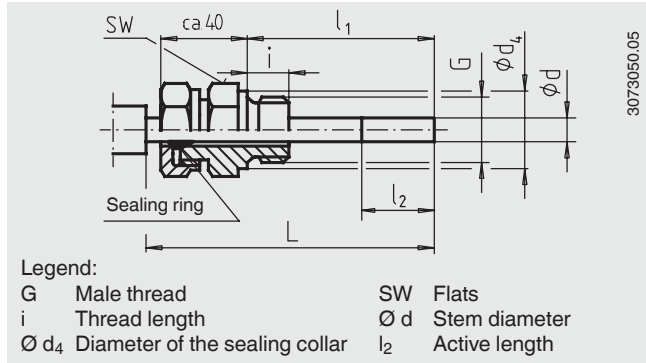

Dimensions in mm

Back mount (BM)

(up to 250 °C)

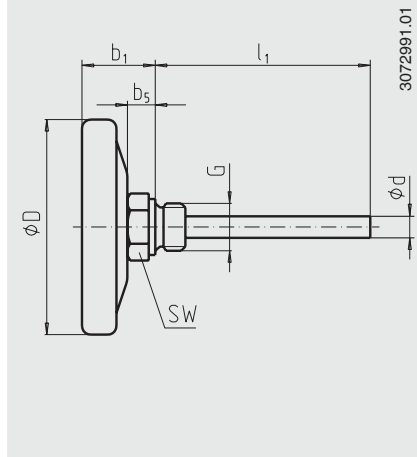

Back mount with spacer

(from 300 °C or on request)

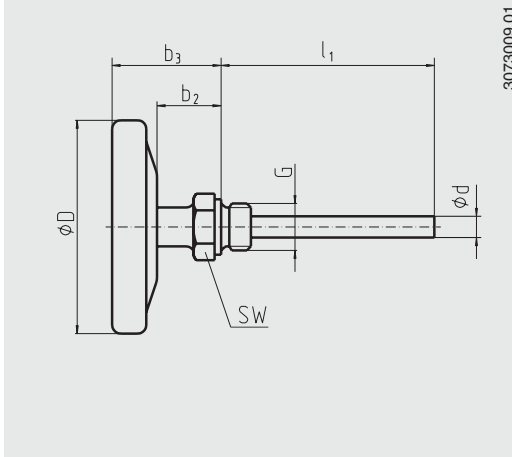

Lower mount (LM)

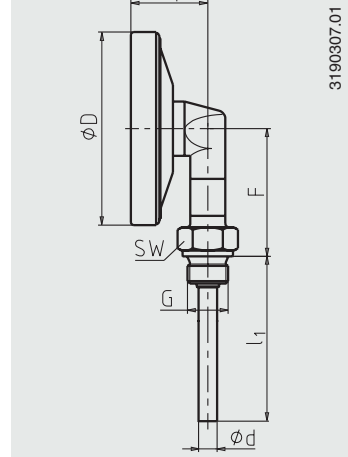

NS	Dimensions in mm						Weight in kg			
	b_1	b_2	b_3	b_4	b_5	$\varnothing D$	F	R	RD	U
25	12/16	-	-	-	2/6	25	-	0.035	-	-
33	12/16	-	-	-	2/6	33	-	0.040	-	-
40	21	-	-	-	8	40	-	0.050	-	-
50	21	-	-	-	8	50	-	0.060	-	-
63	29	30 ¹⁾	46	34	13	63	47	0.160	0.200	0.220
80	30	30 ¹⁾	47	36	13	80	56	0.200	0.240	0.270
100	35	30 ¹⁾	52	40	13	100	66	0.250	0.290	0.330
160	39	30 ¹⁾	57	42.5	13	160	96	0.450	0.490	0.560

1) from 300 °C or on request

R Back mount (BM)

RD Back mount with spacer

U Lower mount (LM)

Thermowell

At pressures greater than 10 bar, high flow rates and highly viscous media, the use of a thermowell is recommended.

With a thermowell, one can remove the thermometer without compromising the sealing of the system or stopping the process (i.e. for instrument replacement or calibration).

Comprehensive WIKA thermowell portfolio, see www.wika.de.

Approvals (option)

- GOST, metrology, measurement technology, Russia
- CRN, safety (e.g. electr. safety, overpressure, ...), Canada

Certificates (option)

- 2.2 test report
- DKD/DakKS calibration certificate

Approvals and certificates, see website

Ordering information

Model / Design of connection / Scale range / Process connection / Stem diameter, material / Insertion length / Options

© 2004 WIKA Alexander Wiegand SE & Co. KG, all rights reserved.
The specifications given in this document represent the state of engineering at the time of publishing.
We reserve the right to make modifications to the specifications and materials.

