

Bourdon tube pressure gauge with switch contacts Models PGS21.1x0, industrial series

WIKA data sheet PV 22.01



switchGAUGE

Applications

- Control and regulation of industrial processes
- Monitoring of plants and switching of electric circuits
- For gaseous and liquid media that are not highly viscous or crystallising and will not attack copper alloy parts

Special features

- High reliability and long service life
- Up to 4 switch contacts per instrument
- Gauges with inductive contacts for use in hazardous areas with ATEX approval
- Gauges with electronic contact for PLC applications
- Contact gauges comply with DIN 16085



Bourdon tube pressure gauge model PGS21.100 with switch contact model 821.21

Description

Wherever the process pressure has to be indicated locally, and, at the same time, circuits are to be made or broken, the model PGS21.1x0 switchGAUGE can be used.

Switch contacts (electrical alarm contacts) make or break an electric control circuit dependent upon the position of the instrument pointer. The switch contacts are adjustable over the full extent of the scale range (see DIN 16085), and are mounted predominantly below the dial, though also partly on top of the dial. The instrument pointer (actual value pointer) moves freely across the entire scale range, independent of the setting.

The set pointer can be adjusted using a removable adjustment key in the window.

Switch contacts consisting of several contacts can also be set to a single set point. Contact actuation is made when the actual value pointer travels beyond or below the desired set point.

The pressure gauge is manufactured in accordance with DIN 16085 and fulfils all requirements of the relevant standards (EN 837-1) and regulations for the on-site display of the working pressure of pressure vessels.

As switch contacts magnetic snap-action contacts, reed switches, inductive contacts - for requirements to ATEX - or electronic contacts for triggering a PLC are available. For further information on the different switch contacts please see data sheet AC 08.01.

Standard version

Nominal size in mm

100, 160

Accuracy class

1.0

Scale ranges

0 ... 0.6 to 0 ... 600 bar

or all other equivalent vacuum or combined pressure and vacuum ranges

Pressure limitation

Steady: Full scale value

Fluctuating: 0.9 x full scale value

Short time: 1.3 x full scale value

Permissible temperature

Ambient: -20 ... +60 °C

Medium: +80 °C maximum

Temperature effect

When the temperature of the measuring system deviates from the reference temperature (+20 °C):

Max. ± 0.4 %/10 K of full scale value

Process connection

Cu-alloy,

lower mount (LM) or lower back mount (LBM)

G ½ B (male), 22 mm flats

Pressure element

< 100 bar: Cu-alloy, C-type

≥ 100 bar: Stainless steel 316L, helical type

Movement

Cu-alloy, wear parts argentan

Dial

Aluminium, white, black lettering

Pointer

Instrument pointer: Aluminium, black

Set pointer: red

Case

Stainless steel

Window

Polycarbonate

Bezel ring

Cam ring (bayonet type), stainless steel

Electrical connection

Terminal box

Ingress protection

IP 54 per EN 60529 / IEC 529

Switch contacts

Magnetic snap-action contact model 821

- No control unit and no extra power supply required
- Direct switching up to 250 V, 1 A
- Up to 4 switch contacts per measuring instrument

Inductive contact model 831

- Long service life due to non-contact sensor
- Additional control unit required (model 904.xx)
- With corresponding control unit suitable for use in zone 1 / 21 (2 GD) hazardous areas
- Low effect on the indication accuracy
- Fail-safe switching at high switching rates
- Insensitive to corrosion
- Up to 3 switch contacts per measuring instrument

Electronic contact model 830 E

- For direct triggering of a programmable logic controller (PLC)
- 2-wire system (option: 3-wire system)
- Long service life due to non-contact sensor
- Low effect on the indication accuracy
- Fail-safe switching at high switching rates
- Insensitive to corrosion
- Up to 3 switch contacts per measuring instrument

Reed switch model 851

- No control unit and no extra power supply required
- Direct switching up to 250 V, 1 A
- Also suitable for direct triggering of a programmable logic controller (PLC)
- Free from wear as without contact
- Up to two change-over contacts per measuring instrument

Switching function

The switching function of the switch is indicated by function index 1, 2 or 3.

Model 8xx.1: Contact makes (clockwise pointer motion)

Model 8xx.2: Contact breaks (clockwise pointer motion)

Models 821.3 and 851.3: Change over; one contact breaks and one contact makes simultaneously when pointer reaches set point

For further information please see data sheet AC 08.01, electrical switch contacts

Options

- Other process connection
- Sealings (model 910.17, see data sheet AC 09.08)
- Inductive contacts also in safety version (SN, S1N)
- Dual scale
- Higher medium temperature
- Panel mounting flange, polished stainless steel
- Surface mounting lugs on the back, stainless steel

Dimensions in mm

switchGAUGE model PGS21.100 with switch contact model 821, 831 or 830 E

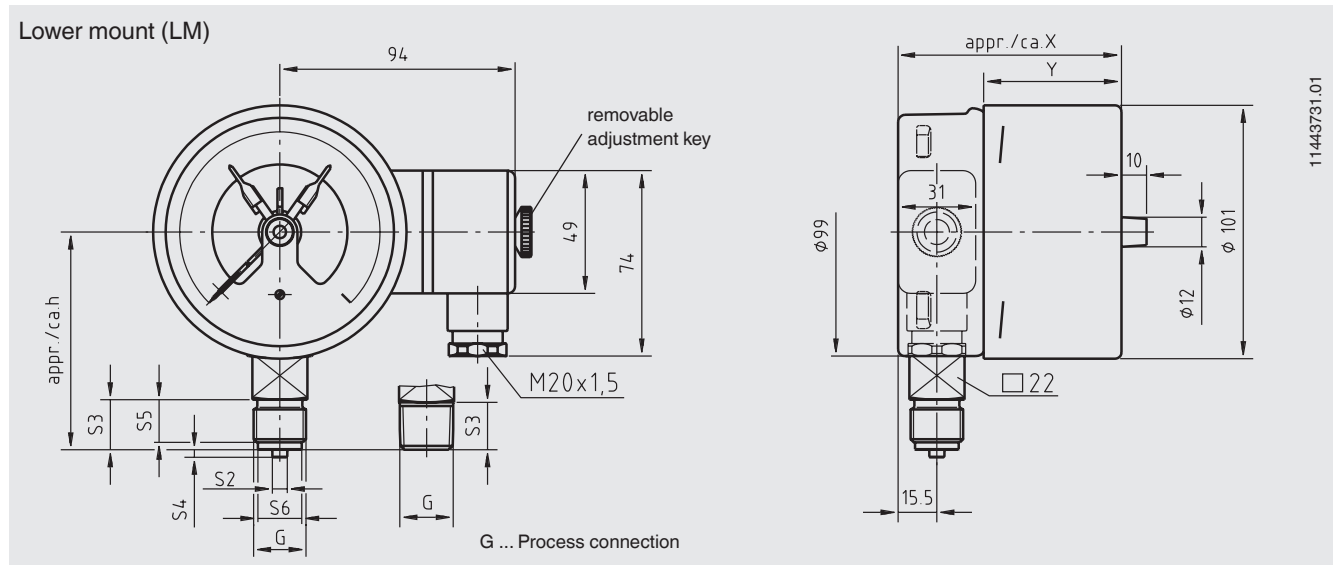

Type of contact	Dimensions in mm	
	X	Y
Single or double contact	88	55
Double contact (SPDT)	113	80
Triple contact	96	63
Quadruple contact	113	80

Process connection	Dimensions in mm					
	h ±1	S2	S3	S4	S5	S6
G ½ B	87	6	20	3	17	17.5
G ¼ B	80	5	13	2	11	9.5
G 3/8 B	83	5.5	16	3	14	13
½ NPT	86	-	19	-	-	-

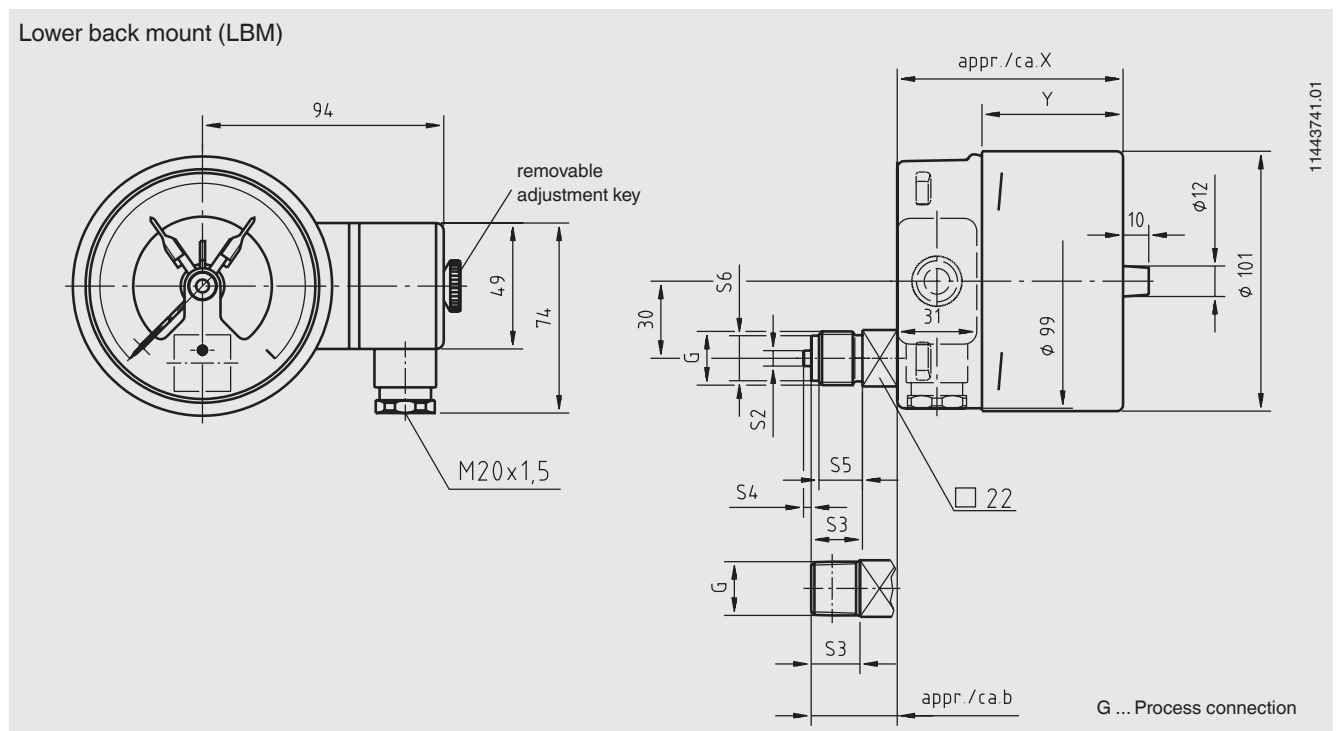

Type of contact	Dimensions in mm	
	X	Y
Single or double contact	88	55
Double contact (SPDT)	113	80
Triple contact	96	63
Quadruple contact	113	80

Process connection	Dimensions in mm					
	b	S2	S3	S4	S5	S6
G ½ B	33.5	6	20	3	17	17.5
G ¼ B	26.5	5	13	2	11	9.5
G 3/8 B	29.5	5.5	16	3	14	13
½ NPT	32.5	-	19	-	-	-

switchGAUGE model PGS21.160 with switch contact model 821, 831 or 830 E

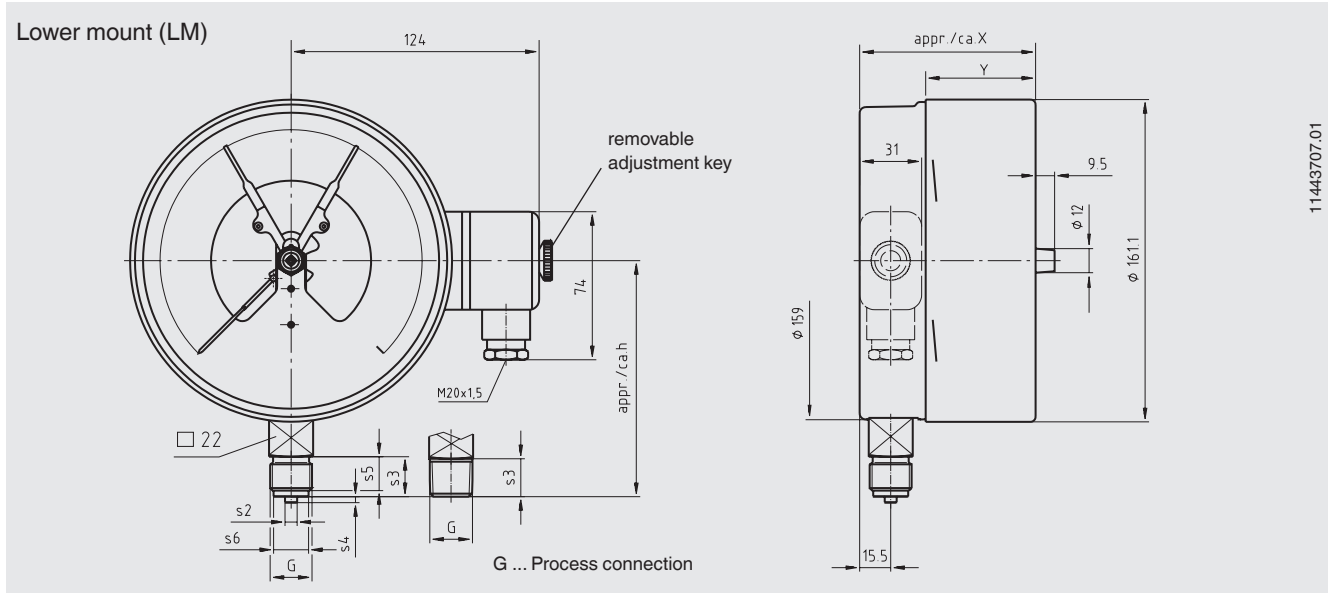

11443707.01

Type of contact	Dimensions in mm	
	X	Y
Single or double contact	88	55
Triple contact	96	63
Quadruple contact	113	80

Process connection	Dimensions in mm					
	h ±1	S2	S3	S4	S5	S6
G ½ B	118	6	20	3	17	17.5
G ¼ B	111	5	13	2	11	9.5
G 3/8 B	114	5.5	16	3	14	13
½ NPT	117	-	19	-	-	-

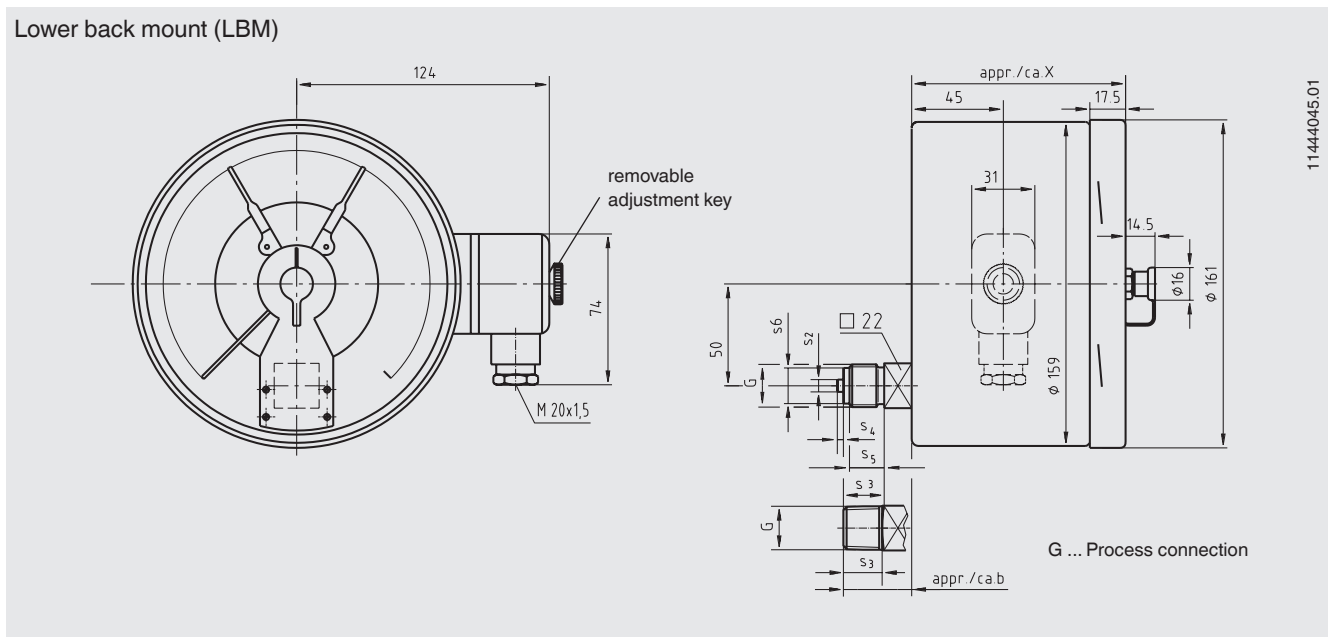

11444045.01

Type of contact	Dimensions in mm
	X
Single or double contact	105
Triple contact	105
Quadruple contact	119

Process connection	Dimensions in mm					
	b	S2	S3	S4	S5	S6
G ½ B	33.5	6	20	3	17	17.5
G ¼ B	26.5	5	13	2	11	9.5
G 3/8 B	29.5	5,5	16	3	14	13
½ NPT	32.5	-	19	-	-	-

switchGAUGE model PGS21.100 with switch contact model 851.3 or 851.33

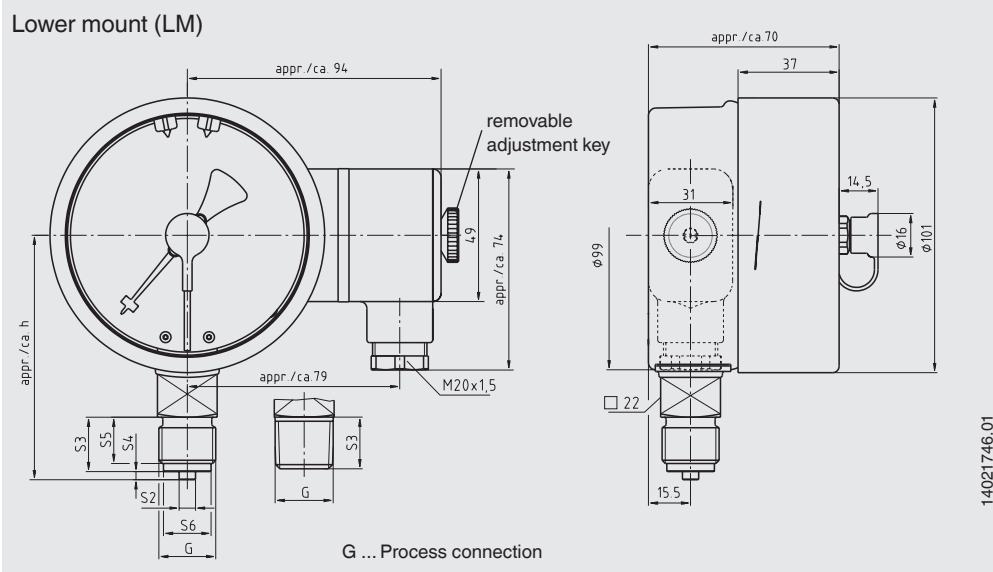

Process connection	Dimensions in mm					
	h ±1	S2	S3	S4	S5	S6
G ½ B	87	6	20	3	17	17.5
G ¼ B	80	5	13	2	11	9.5
G 3/8 B	83	5.5	16	3	14	13
½ NPT	86	-	19	-	-	-

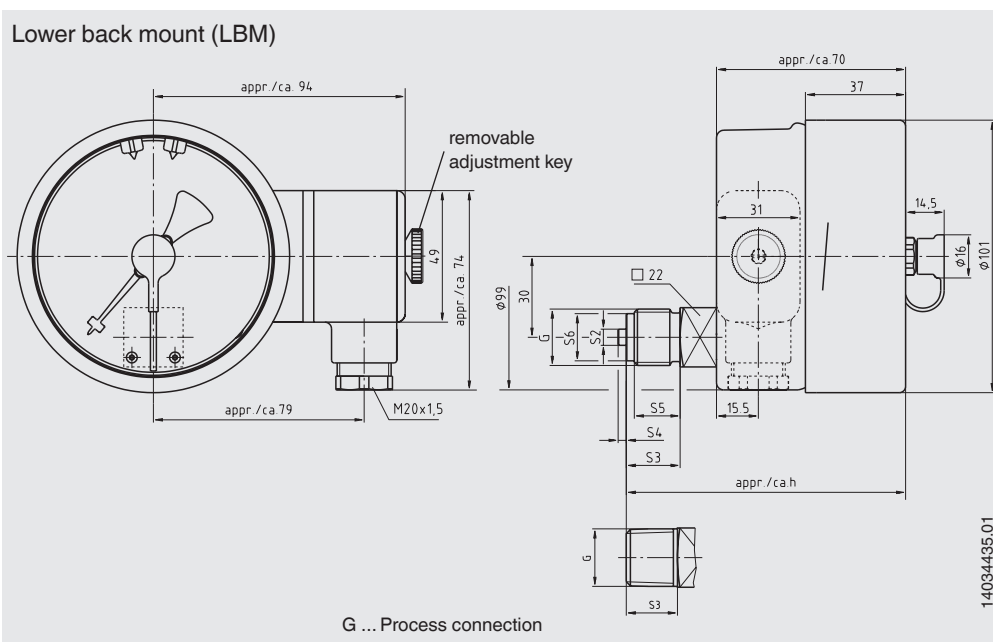

Process connection	Dimensions in mm					
	h ±1	S2	S3	S4	S5	S6
G ½ B	103	6	20	3	17	17.5
G ¼ B	96	5	13	2	11	9.5
G 3/8 B	99	5.5	16	3	14	13
½ NPT	102	-	19	-	-	-

switchGAUGE model PGS21.160 with switch contact model 851.3 or 851.33

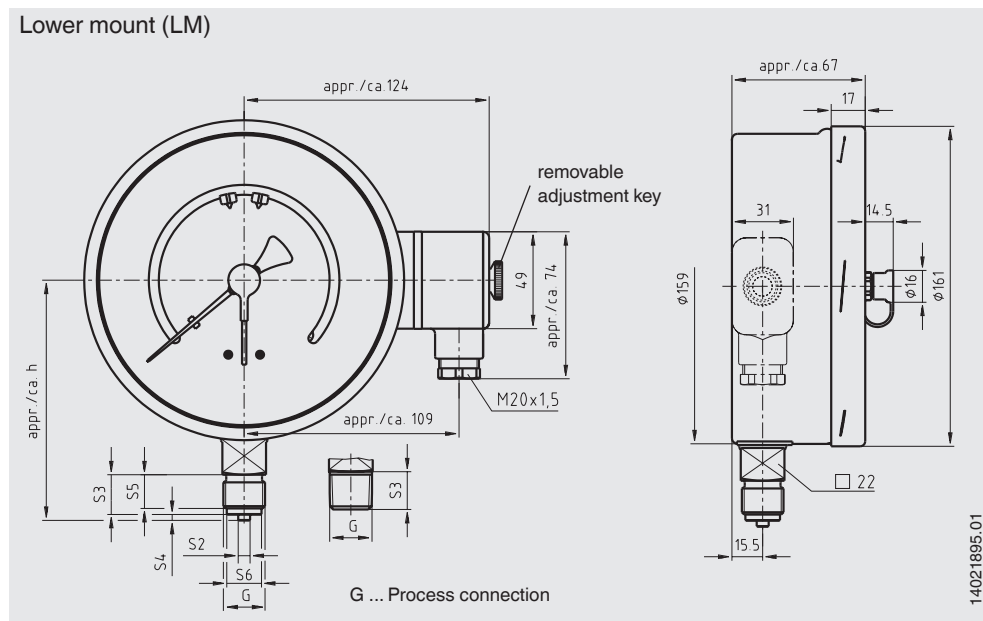

Process connection	Dimensions in mm					
	h ±1	S2	S3	S4	S5	S6
G ½ B	118	6	20	3	17	17.5
G ¼ B	111	5	13	2	11	9.5
G 3/8 B	114	5.5	16	3	14	13
½ NPT	117	-	19	-	-	-

Ordering information

Model / Nominal size / Type of contact and switching function / Scale range / Connection size / Connection location / Options

© 2009 WIKA Alexander Wiegand SE & Co. KG, all rights reserved.
 The specifications given in this document represent the state of engineering at the time of publishing.
 We reserve the right to make modifications to the specifications and materials.



WIKAL
 WIKAL Alexander Wiegand SE & Co. KG
 Alexander-Wiegand-Straße 30
 63911 Klingenberg/Germany
 Tel. (+49) 9372/132-0
 Fax (+49) 9372/132-406
 E-mail info@wika.de
 www.wika.de