



Machine glass thermometers Model 32, V-Form

WIKA data sheet TM 32.02



for further approvals
see page 5

Applications

- Universal application
- Machine building
- Vessel construction
- Central and large heating systems
- Plant construction

Special features

- Insensitive to vibrations
- Non-toxic thermometric liquid
- Measuring ranges from -30 ... +200 °C



Machine glass thermometer model 32, 90° angle version

Description

The model 32 machine glass thermometer is mainly used in industrial applications such as machine building and also in heating, air-conditioning and refrigeration technology.

It is notable for its high accuracy and very long service life (since there is no mechanical wear).

Standard version

Nominal size in mm

110, 150 and 200

Measuring principle

Liquid expansion

Error limit

DIN 16195

Permissible working pressure at the stem

Max. 6 bar

Stem

Ø 10 mm

Ø 6.5 mm for NS 200 x 36 with union nut M24 x 1.5

Case

Aluminium, brass-coloured, anodised

Scale setting

printed with special ink, protected by anodised finish

Thermometer glass insert

Rod shape, prismatic capillary

Thermometric liquid

Blue, wetting

Nominal size 110 x 30 mm

Connection type

Design E, male thread

■ Straight design per DIN 16181

Threaded connection

- G ½ B, M20 x 1.5 (form B per DIN)

- G ¾ B, M16 x 1.5 (form B1 per DIN)

Threaded connections screwed into housing

Insertion length l_1 = 30, 40, 63, 100, 160, 250 mm

Copper alloy

■ 90° angle version per DIN 16182

Threaded connection

- G ½ B, M20 x 1.5 (form S per DIN)

- G ¾ B, M16 x 1.5 (form S1 per DIN)

Threaded connectors inserted into housing, removable

Insertion length l_1 = 30, 40, 63, 100, 160, 250 mm

Copper alloy

■ 135° angle version

Threaded connection

- G ½ B, M20 x 1.5

- G ¾ B, M16 x 1.5

Threaded connections screwed into housing

Insertion length l_1 = 30, 40, 63, 100, 160, 250 mm

Copper alloy

Nominal size 150 x 36 mm

Connection type

Design E, male thread

■ Straight design per DIN 16185

Threaded connection

- G ½ B, M20 x 1.5 (form B per DIN)

- G ¾ B, M27 x 2

Threaded connections screwed into housing

Insertion length l_1 = 63, 100, 160, 250 mm

Copper alloy

■ 90° angle version per DIN 16186

Threaded connection

- G ½ B, M20 x 1.5 (form S per DIN)

- G ¾ B, M27 x 2

Threaded connectors inserted into housing, removable

Insertion length l_1 = 63, 100, 160, 250 mm

Copper alloy

■ 135° angle version

Threaded connection

- G ½ B, M20 x 1.5

- G ¾ B, M27 x 2

Threaded connections screwed into housing

Insertion length l_1 = 63, 100, 160, 250 mm

Copper alloy

Nominal size 200 x 36 mm

Connection type

Design E, male thread

■ Straight design per DIN 16189

Threaded connection

- G ½ B, M20 x 1.5 (form B1 per DIN)

- G ¾ B, M27 x 2 (form B per DIN)

Threaded connections screwed into housing

Insertion length l_1 = 63, 100, 160, 250 mm

Copper alloy

■ 90° angle version per DIN 16190

Threaded connection

- G ½ B, M20 x 1.5 (form S1 per DIN)

- G ¾ B, M27 x 2 (form S per DIN)

Threaded connectors inserted into housing, removable

Insertion length l_1 = 63, 100, 160, 250 mm

Copper alloy

■ 135° angle version

Threaded connection

- G ½ B, M20 x 1.5 (form B1 per DIN)

- G ¾ B, M27 x 2 (form B per DIN)

Threaded connections screwed into housing

Insertion length l_1 = 63, 100, 160, 250 mm

Copper alloy

Scale ranges

Nominal size in mm	Scale range in °C	Scale spacing in °C	Error limit in °C
NS 110	-30 ... +50	1	2
	0 ... 60	1	1.5
	0 ... 100	2	2
	0 ... 120	2	2
	0 ... 160	4	4
	0 ... 200	5	5
NS 150	-30 ... +50	1	2
	0 ... 60	1	1.5
	0 ... 100	2	2
	0 ... 120	2	2
	0 ... 160	2	4
	0 ... 200	2	4
NS 200	-30 ... +50	1	2
	0 ... 60	1	1.5
	0 ... 100	1	2
	0 ... 120	1	2
	0 ... 160	2	4
	0 ... 200	2	4

Models

Nominal size in mm	Model	Connection location	DIN
NS 110	G 3200	straight	DIN 16181
	W 3201	90° angle	DIN 16182
	W 3202	135° angle	-
NS 150	G 3210	straight	DIN 16185
	W 3211	90° angle	DIN 16186
	W 3212	135° angle	-
NS 200	G 3220	straight	DIN 16189
	W 3221	90° angle	DIN 16190
	W 3222	135° angle	DIN 16191

Options (for all nominal sizes)

- Dual scale °F/°C
- Other scale ranges
- Threaded connections from other materials
- Thermowells in accordance with DIN from copper alloy, steel, stainless steel or other materials
- Connection design (selectable): Design 3, union nut
- Variants
 - **Straight design per DIN 16189**
 - Union nut
 - G 1/2, M20 x 1.5 (form C1 per DIN)
 - G 3/4, M27 x 2 (form C per DIN)
 - M24 x 1.5 (form F per DIN)
 - Adapter screwed into housing, removable
 - Insertion length l_1 :
 - Form C1: $l_1 = 89, 126, 186, 276, 426$ mm
 - Form C: $l_1 = 93, 130, 190, 280, 430$ mm
 - Form F: $l_1 = 155, 215, 275, 295, 355, 415$ mm
 - Union nut and copper alloy adapter, pipe st. 35

- 90° angle version per DIN 16190

- Union nut
 - G 1/2, M20 x 1.5 (form C1 per DIN)
 - G 3/4, M27 x 2 (form C per DIN)
 - M24 x 1.5 (form F per DIN)
- Adapter inserted into housing, removable
- Insertion length l_1 :
 - Form C1: $l_1 = 89, 126, 186, 276, 426$ mm
 - Form C: $l_1 = 93, 130, 190, 280, 430$ mm
 - Form F: $l_1 = 155, 215, 275, 295, 355, 415$ mm
- Union nut and copper alloy adapter, pipe st. 35

- 135° angle version per DIN 16191

- Union nut
 - G 1/2, M20 x 1.5 (form C1 per DIN)
 - G 3/4, M27 x 2 (form C per DIN)
 - M24 x 1.5 (form F per DIN)
- Adapter screwed into housing, removable
- Insertion length l_1 :
 - Form C1: $l_1 = 89, 126, 186, 276, 426$ mm
 - Form C: $l_1 = 93, 130, 190, 280, 430$ mm
 - Form F: $l_1 = 155, 215, 275, 295, 355, 415$ mm
- Union nut and copper alloy adapter, pipe st. 35

Dimensions in mm

Connection design E, male thread

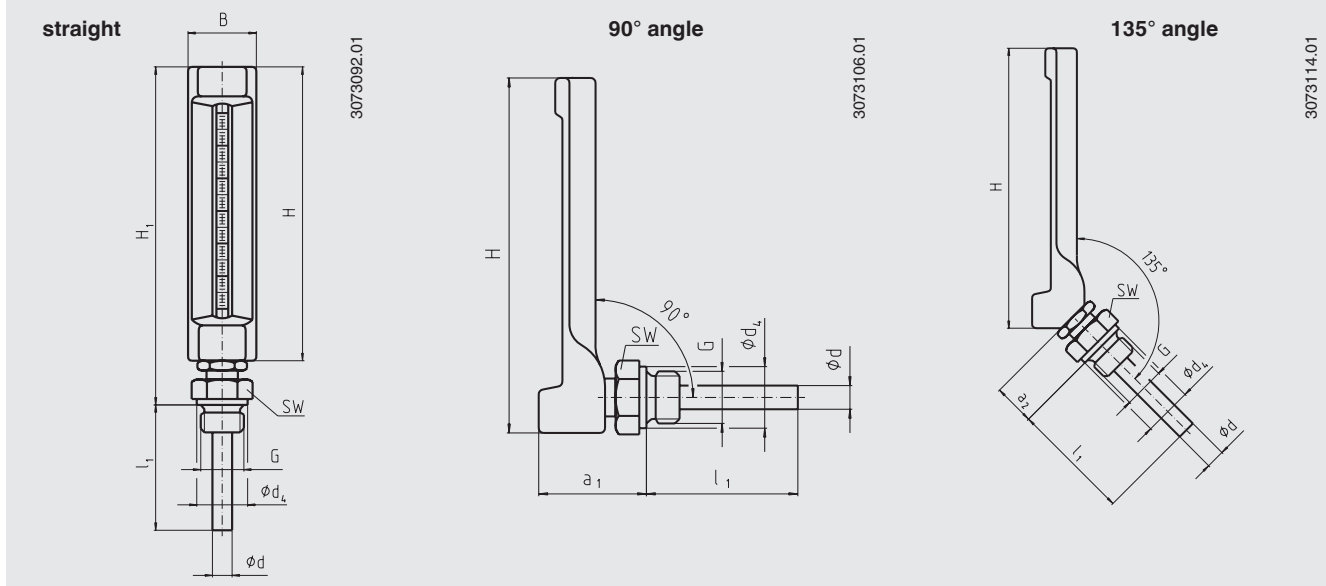

Connection design 3, union nut (only with NS 200)

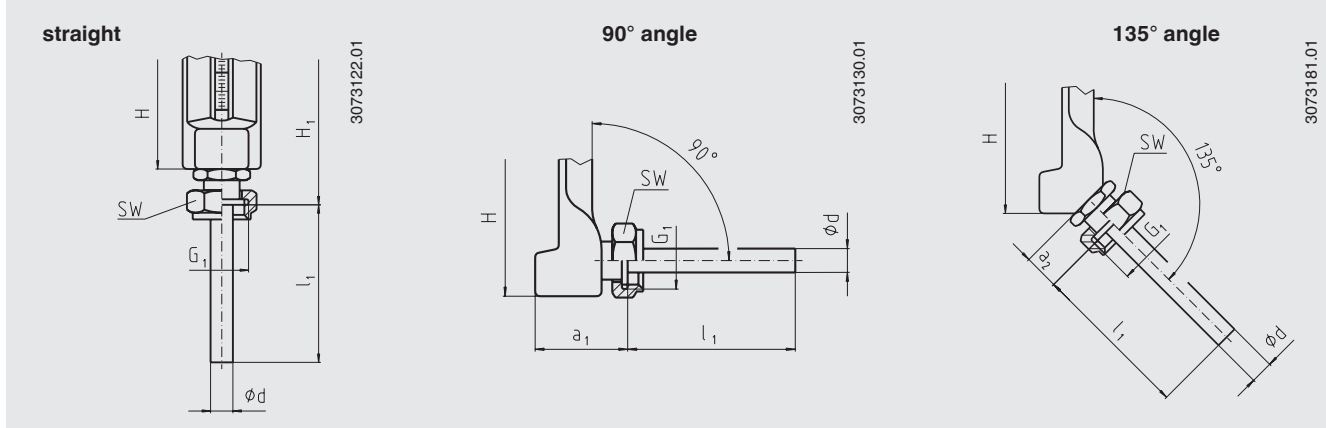

NS	Dimensions in mm										Weight in kg
	a ₁	a ₂	B	Ø d	Ø d ₁	G	G ₁	H	H ₁	SW	
110	44	20	30	10	22	G 3/8 B	-	110	130	22	0.25
	44	20	30	10	21	M16 x 1.5	-	110	130	22	0.25
	44	20	30	10	26	G 1/2 B	-	110	130	27	0.25
	44	20	30	10	25	M20 x 1.5	-	110	130	27	0.25
150	46	21	36	10	26	G 1/2 B	-	150	170	27	0.30
	46	21	36	10	25	M20 x 1.5	-	150	170	27	0.30
	46	21	36	10	32	G 3/4 B	-	150	170	32	0.30
	46	21	36	10	32	M27 x 2	-	150	170	32	0.30
200	46	21	36	10	26	G 1/2 B	G 1/2	200	220	27	0.35
	46	21	36	10	25	M20 x 1.5	M20 x 1.5	200	220	27	0.35
	46	21	36	10	32	G 3/4 B	G 3/4	200	220	32	0.35
	46	21	36	10	32	M27 x 2	M27 x 2	200	220	32	0.35
	46	21	36	6.5	-	-	M24 x 1.5	200	220	32	0.35

Approvals

- **GL** ¹⁾, ships, shipbuilding (e.g. offshore), Germany
- **CRN**, safety (e.g. electr. safety, overpressure, ...), Canada

1) For straight and 90° angle versions

Approvals and certificates, see website

Ordering information

Model / Nominal size / Scale range / Connection design / Length l_1 / Options

© 2008 WIKA Alexander Wiegand SE & Co. KG, all rights reserved.
The specifications given in this document represent the state of engineering at the time of publishing.
We reserve the right to make modifications to the specifications and materials.

